



# Series 40C Pumps



The Series 40C pump has been designed for simplistic operation and easy maintenance.

The Series 40C is an ideal pump for above ground swimming pools and small re-circulation systems including ponds and small water features.

## Series 40C Pumps

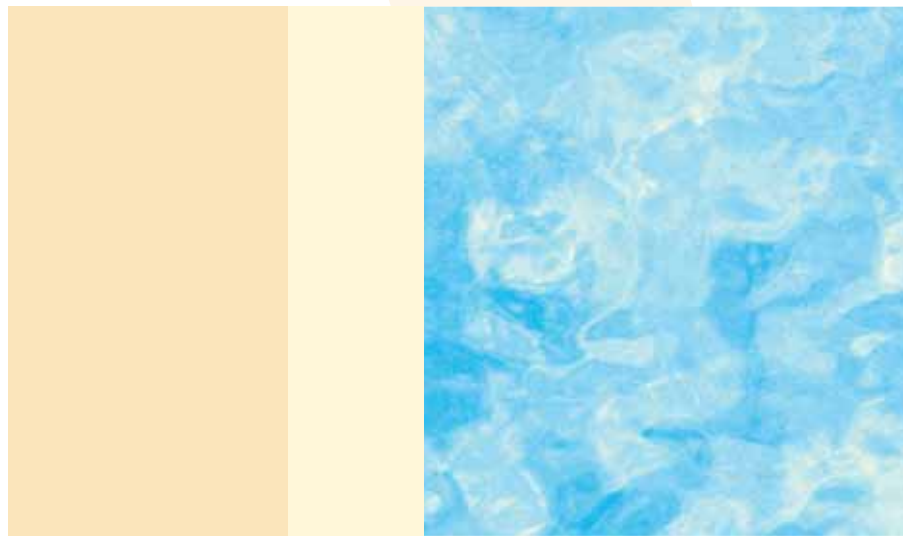

*Clean Water Through Superior Technology*



# Series 40C Pumps

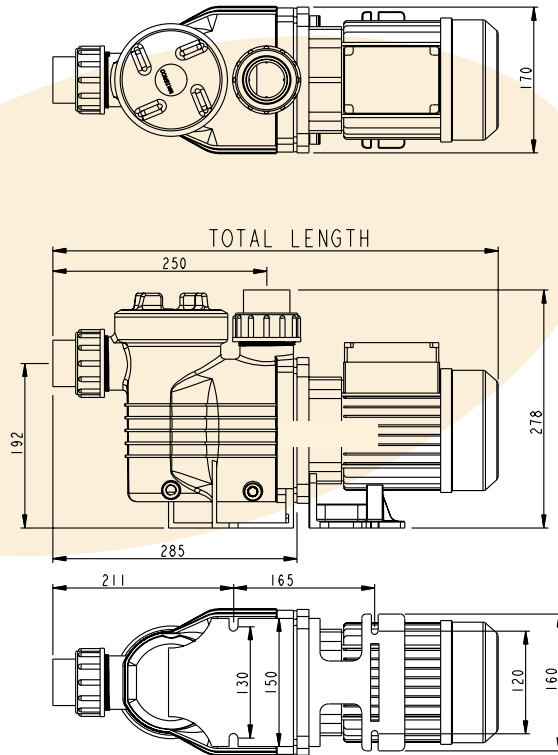
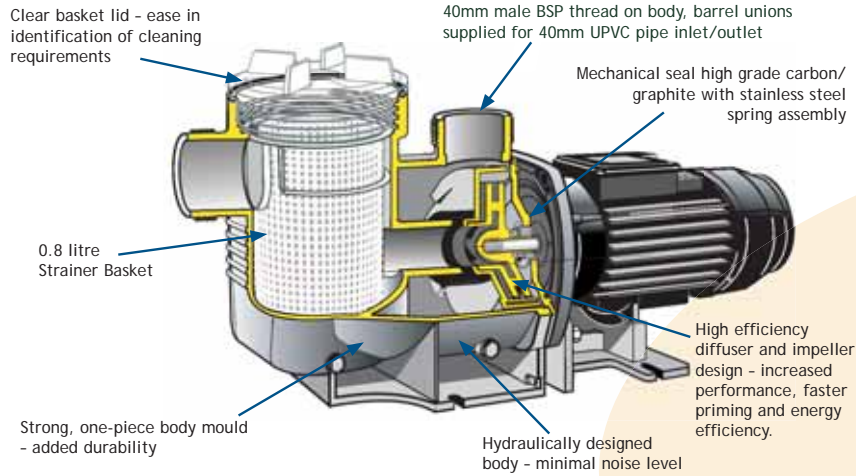

## Efficient Impeller and Diffuser Design

The pump's impeller and diffuser design maximizes the hydraulic output of the pump while minimizing turbulence. The pump's efficient hydraulic performance shortens run times and reduces energy consumption leading to lower operating costs.

## Engineered Durability

The pump body is manufactured utilising state of the art engineering plastic moulding with a single piece strainer pot and volute for extra strength.

Series 40C pump performance chart

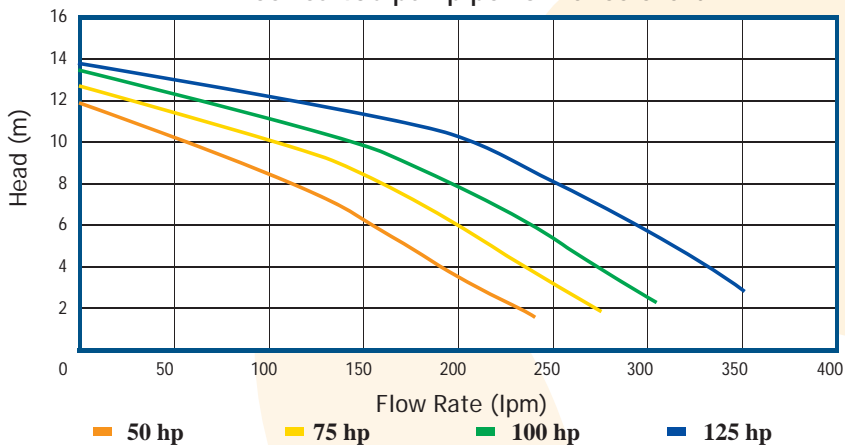

Code	Pump Model	Phase	HP	KW	Amps	Motor Frame	Total Length
2402050A	50	1	0.50	0.58	2.50	63	497
2402075A	75	1	0.75	0.65	3.00	63	497
2402100A	100	1	1.00	0.76	3.33	71	520
2402125A	125	1	1.25	0.88	3.90	71	520

Phase	Volts	Cycle	RPM	Pump Rating
1	220 - 240	50	2860	IPX5

## Warranty

Aquaswim pumps are covered by a comprehensive 2 year warranty for residential installations and a comprehensive 1 year warranty for commercial installations.



NSW	QLD	VIC/TAS	WA	SA/NT
Sydney (Head Office)	Brisbane	Melbourne	Perth	Adelaide
Tel: (02) 9898 8686	Tel: (07) 3299 9955	Tel: (03) 9879 8855	Tel: (08) 9273 1900	Tel: (08) 8244 6000
Fax: (02) 9898 1754	Fax: (07) 3299 9911	Fax: (03) 9879 5143	Fax: (08) 9273 1999	Fax: (08) 8244 6011

**DISTRIBUTED BY**

ZZA0949 07/04

In the interest of providing better quality and value we are constantly improving and updating our product. Consequently, pictures and information on our brochures may sometimes vary slightly from models available.