



Series 40S Pumps



State of the Art Power

Series 40S pumps are general purpose pumps designed for use in swimming pools and low pressure water re-circulation applications.

Series 40S Pumps



Clean Water Through Superior Technology



Series 40S Pumps

Clear basket lid - ease in identification of cleaning requirements

40mm male BSP threaded on body, barrel unions supplied for 40mm UPVC pipe inlet/outlet

316 Mechanical seal - High grade Carbon/Graphite with 316 stainless steel

1.45 litre Strainer Basket

Pump body - Glass Filled Thermoplastic

Drain plugs

Impeller/diffuser - Glass filled Noryl.

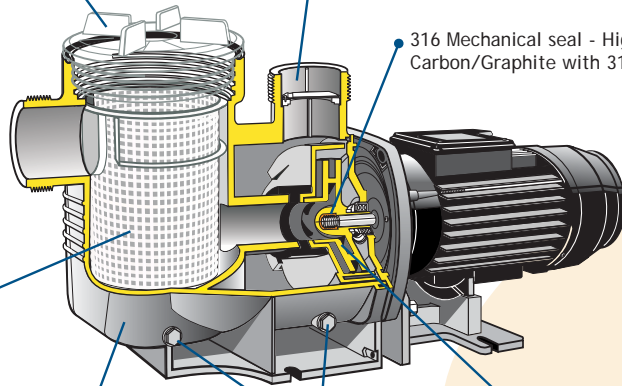

Motor:

- Motor shaft 303 grade stainless steel.
- Fan cooled.
- Thermal overload
- Insect and Vermin resistant.

Efficient Impeller and Diffuser Design

The pump's impeller and diffuser design maximizes the hydraulic output of the pump while minimizing turbulence. The pump's efficient hydraulic performance shortens run times and reduces energy consumption leading to lower operating costs.

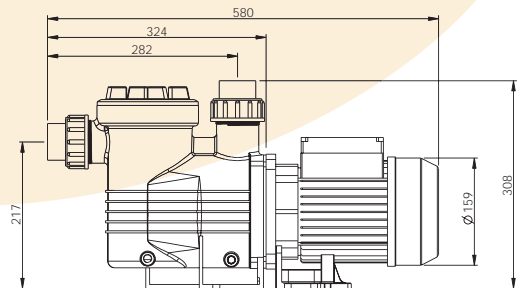

Engineered Durability

The pump body is manufactured utilising state of the art engineering plastic moulding with a single piece strainer pot and volute for extra strength. A high grade 316 stainless steel mechanical seal is incorporated for extra protection against corrosion e.g. from chlorinated water, ozone, iodine, Baquacil, bromine and salt water.

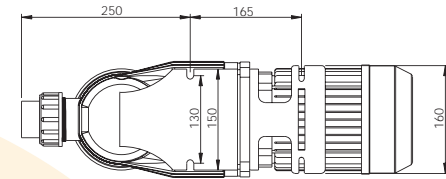

Series 40S Pump Performance Curves

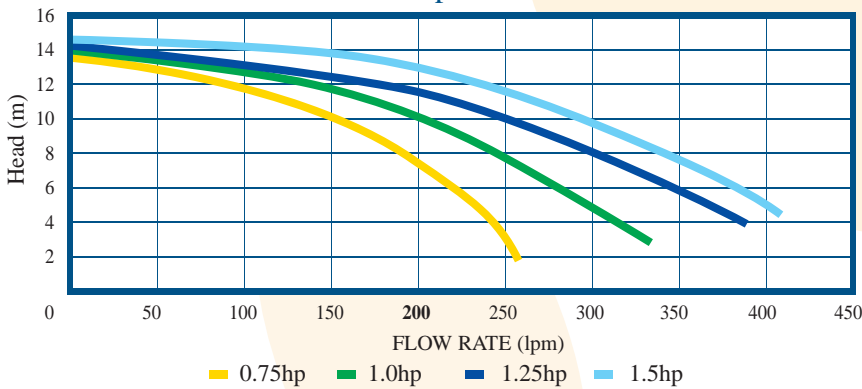

Model	Phase	HP	KW	Amps	Motor Frame	Total Length
2403075A	1	0.75	0.73	3.20	71	587
2403100A	1	1.00	0.82	3.60	71	587
2403125A	1	1.25	0.96	4.20	80	608
2403150A	1	1.50	1.09	4.80	80	629

Phase	Volts	Cycle	RPM	Pump Rating
1	220 - 240	50	2860	IPX5

Warranty

Aquaswim pumps are covered by a comprehensive 2 year warranty for residential installations and a comprehensive 1 year warranty for commercial installations.



NSW

Sydney (Head Office)
Tel: (02) 9898 8600
Fax: (02) 9898 1877

QLD

Brisbane
Tel: (07) 3299 9900
Fax: (07) 3299 9911

VIC/TAS

Melbourne
Tel: (03) 9879 5141
Fax: (03) 9879 5143

WA

Perth
Tel: (08) 9273 1900
Fax: (08) 9273 1999

SA/NT

Adelaide
Tel: (08) 8244 6000
Fax: (08) 8244 6011

ACT Distributor

Canberra
Tel: (02) 6280 6476
Fax: (02) 6239 139

DISTRIBUTED BY

ZZA1033 07/04

In the interest of providing better quality and value we are constantly improving and updating our product. Consequently, pictures and information on our brochures may sometimes vary slightly from models available.