

# Series 50t Pumps



Delivers extra power and higher performance for larger pools

The Series 50T is designed to have all the extra power you need to cope with modern day swimming pool designs which can include other ancillary systems like heating, infloor cleaning, fountains, vacuum cleaning and swim jets. The new Series 50T pump is an energy saving device that caters for growing needs and requirements of customers in the pool and spa industry and will provide durable, quality service.

## Series 50T Pumps



*Clean Water Through Superior Technology*

# Series 50T Pumps

50mm male BSP thread on body, barrel unions supplied for 50mm UPVC pipe inlet/outlet

Lid - Polycarbonate materials

316 Mechanical seal - High grade Carbon/Graphite with 316 stainless steel

2.1 litre Strainer Basket - optimize hydraulic flow and maximize the debris holding capacity

Pump body - Glass Filled Thermoplastic

Drain plugs

Impeller/diffuser - Glass filled Noryl.

Motor:

- IP55 rating
- Motor shaft 303 grade stainless steel.
- Fan cooled.
- Thermal overload
- Insect and vermin resistant.

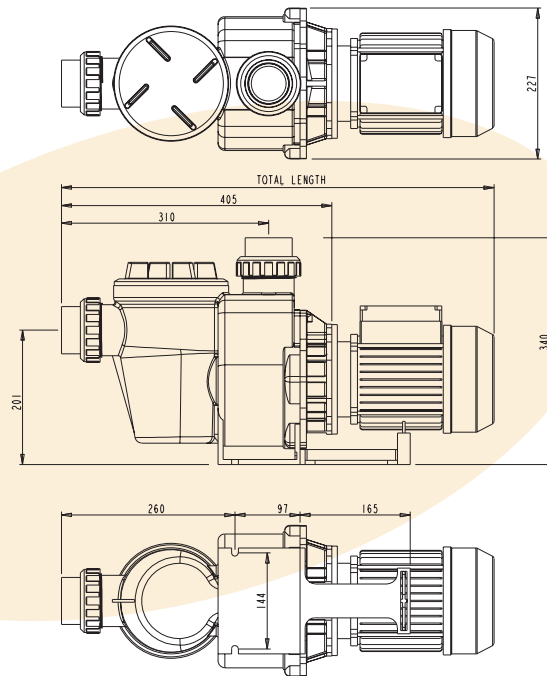

Model	PUMP	HP	KW	Amps	Phase	Total Length	Motor Frame
244100A	100	1.00	0.91	4.00	1	646	80
244125A	125	1.25	1.08	4.80	1	646	80
244150A	150	1.50	1.31	6.00	1	646	80
244200A	200	2.00	1.46	6.60	1	646	80

Phase	Volts	Cycle	RPM	Pump rating
1	220 - 240	50	2860	IPX5

## Efficient Impeller a Design

The pump's impeller and diffuser design maximizes the hydraulic output of the pump while minimizing turbulence. The pump's efficient hydraulic performance shortens run times and reduces energy consumption leading to lower operating costs.

## Engineered Durability

The pump body is manufactured utilising state of the art engineering plastic moulding with a single piece strainer pot and volute for extra strength. And a high grade 316 stainless steel mechanical seal is incorporated for extra protection against corrosion. e.g. chlorinated water, ozone, iodine, Baquacil, bromine and salt water.

## Warranty

Aquaswim pumps are covered by a comprehensive 2 year warranty for residential installations and a comprehensive 1 year warranty for commercial installations.

## Series 50T Pump Performance Curves

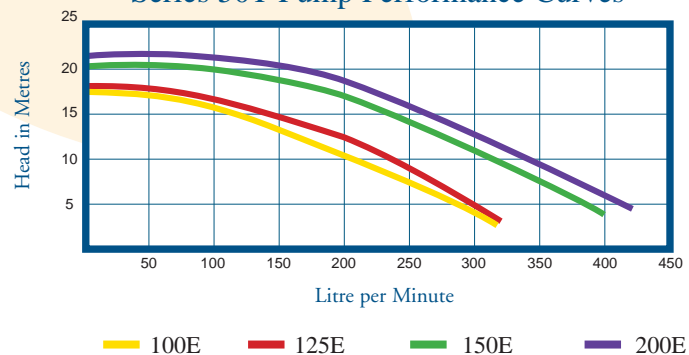

**DISTRIBUTED BY**



<b>NSW</b> Sydney (Head Office) Tel: (02) 9898 8686 Fax: (02) 9898 1754	<b>QLD</b> Brisbane Tel: (07) 3299 9955 Fax: (07) 3299 9911	<b>VIC/TAS</b> Melbourne Tel: (03) 9879 8855 Fax: (03) 9879 5143	<b>WA</b> Perth Tel: (08) 9273 1900 Fax: (08) 9273 1999	<b>SA/NT</b> Adelaide Tel: (08) 8244 6000 Fax: (08) 8244 6011
--	--	---	--	--

ZZA0509 07/04

In the interest of providing better quality and value we are constantly improving and updating our product. Consequently, pictures and information on our brochures may sometimes vary slightly from models available.